

2018

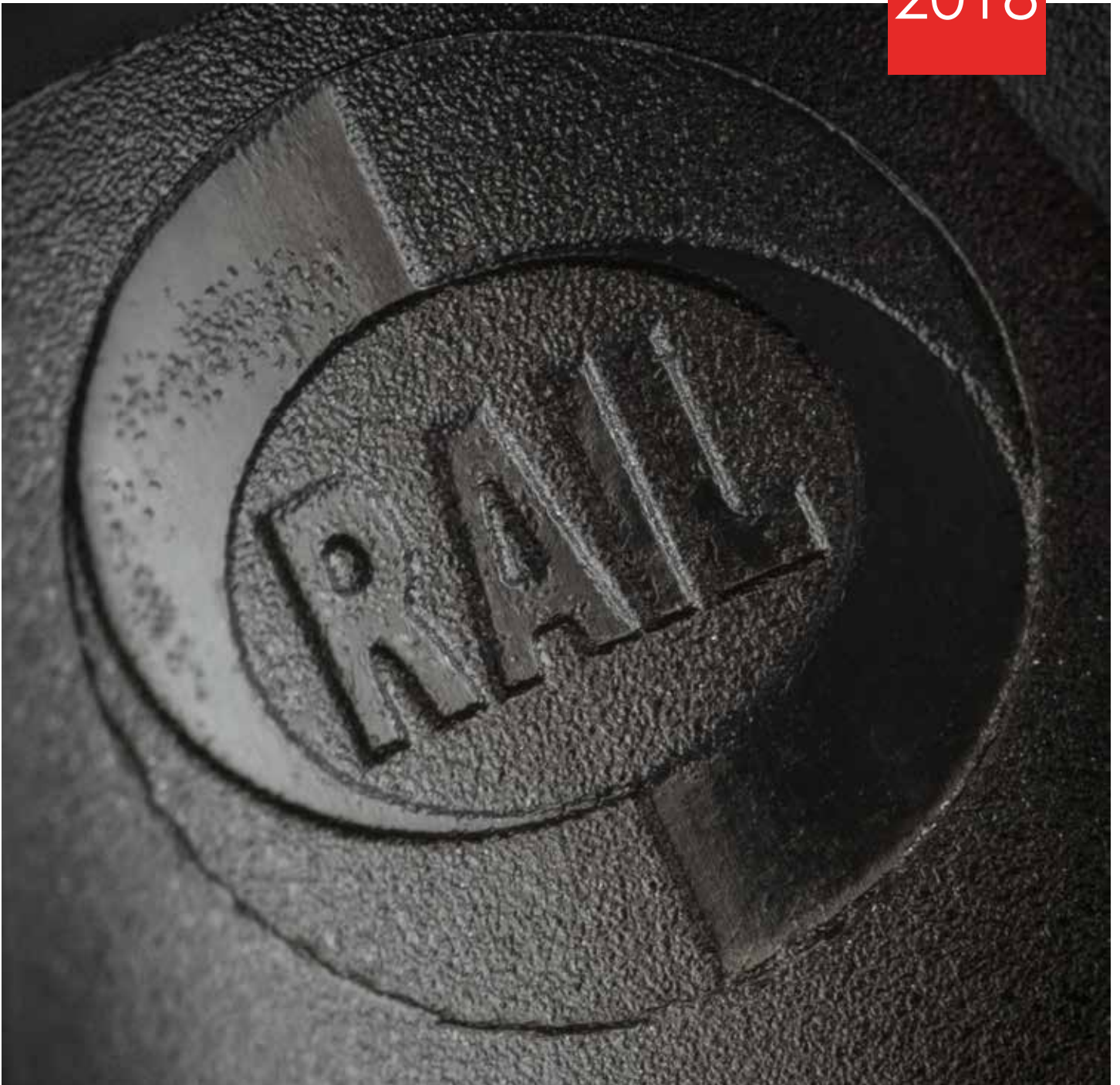

Catalogo
Prodotti GPL/Metano

LPG/CNG Products
Catalogue



www.railgroup.it



2018

Catalogo
Prodotti GPL/Metano

LPG/CNG Products
Catalogue



Indice Index

04	Il gruppo The group	16	Iniettori per applicazioni GPL/Metano Injectors for LPG/CNG application
05	Chi siamo Company profile	17	IG1 Old
06	Ricerca e sviluppo R&D engineering	18	IG1 Apache
07	Nel mondo In the world	19	IG1 Apache HD
08	Raggiungimenti Achievement	20	IG2
09	Progettazione Design	21	IG5 Noumea
10	Riduttore metano CNG reducer	22	IG7 Dakota
11	Iniettoriduttore Injectoreducer	23	Iniettori GPL/Metano per veicoli pesanti LPG/CNG Injectors for Heavy Duty vehicles
12	Personalizzazione Customization	24	IG6 Taurus
14	Caratteristiche Features	25	IG6 Potomac
15	Legenda	26	IG7 Dakota HP
		27	Filtri GPL/Metano LPG/CNG Filters
		29	Elettrovalvola GPL LPG Solenoid valve
		31	Tubo termoplastico GPL LPG Thermoplastic hose
		34	Extra Extras
		36	Accessori Accessories



Produzione e progettazione di componenti per conversioni di auto a GPL/Metano

injector.railgroup.it

Manufacturing and Design of components for LPG/CNG Autogas conversion



Produzione e progettazione di corpi illuminanti a LED

illed.it

Manufacturing and Design of LED Lighting



Business Network dedicato alle aziende di tutto il mondo

keepint.com

Business Network dedicated to worldwide companies



RAIL nasce nel 2006 e progetta, produce e commercializza iniettori per sistemi Gpl/Metano nel settore dell' Automotive. I fondatori Stevani Luigi e Grossi Rocco hanno maturato negli anni la loro esperienza sviluppando, con il tempo, competenze tecniche sempre più specifiche nella progettazione di questi prodotti.

RAIL dispone di uno Staff dinamico e specializzato in grado di mettere in pratica le proprie competenze al servizio del cliente per trovare la soluzione più idonea ad ogni esigenza .

La professionalità e l'impegno sono infatti le principali caratteristiche che contraddistinguono RAIL sul mercato grazie ad una valida consulenza tecnica, in grado di supportare il cliente sia nella fase pre che post vendita.

RAIL dispone di attrezzature specifiche ed all'avanguardia in grado di produrre e collaudare i nostri prodotti, nel rispetto delle norme vigenti di qualità e sicurezza.

Nel corso di questi anni , RAIL ha continuato il suo processo di espansione progettando e producendo diversi modelli di prodotti / iniettori che hanno portato a far conoscere il proprio marchio in oltre 30 paesi in tutto il mondo.

Il continuo investimento nella ricerca e sviluppo di nuovi materiali e/o soluzioni migliorative, ha consentito a RAIL di incrementare la qualità dei propri prodotti, perché riteniamo siano i mezzi necessari per ottenere un unico risultato: la soddisfazione del cliente .

RAIL born in 2006 and Design, Manufacture and sell injector for LPG/CNG system in automotive industry.

The founders Stevani Luigi and Grossi Rocco, acquired experience during years of work, developing always more specific technical skills for the design these products.

RAIL has a dynamic and specialized staff able to put into practice their skills at client's service to find the right solution for every need

The professionalism and dedication are indeed the main characteristics that distinguish RAIL In the market thanks to valuable technical consultation, able to support the customers in pre and post sales phase.

During these years, RAIL continued its expansion process designing and producing different models of products / injectors that came to know RAIL brand in over 30 countries around the world.

RAIL has specific and advanced equipment to produce and test products, in compliance with applicable quality and safety standards.

The continuous investment in research and development of new materials and / or improved solutions, has enabled RAIL to increase the quality of its products, because RAIL has the belief that these are the right instruments to achieve a unique result: The customer satisfaction.

Il nostro laboratorio tecnico, il reparto qualità e la produzione dispongono di attrezzature di alto livello e siamo fortemente orientati al miglioramento continuo, con particolare attenzione all'automazione spinta in ogni fase del ciclo produttivo.

Il nostro reparto industrializzazione prodotti è in grado di studiare soluzioni di automazione che ci hanno consentito notevoli miglioramenti nella fase di calibrazione e controllo finale degli iniettori.

Il voler puntare all'eccellenza ci porterà ad una continua evoluzione e utilizzo degli strumenti più idonei atti a ottenere un elevato standard qualitativo dei nostri prodotti.

Our technical laboratory, quality and production departments have the use of high-level equipments and we are strongly inclined to the endless improvement, with a special attention to the automation prompt in each step of production cycle.

Our products-industrialization department is skilled in examining automation's solutions that have allowed us considerable refinements in the calibration phase and injectors' final check.

To aim to the excellence will bring us to a continuous evolution and use of the most appropriate tooling for obtaining an high standard quality of our products.



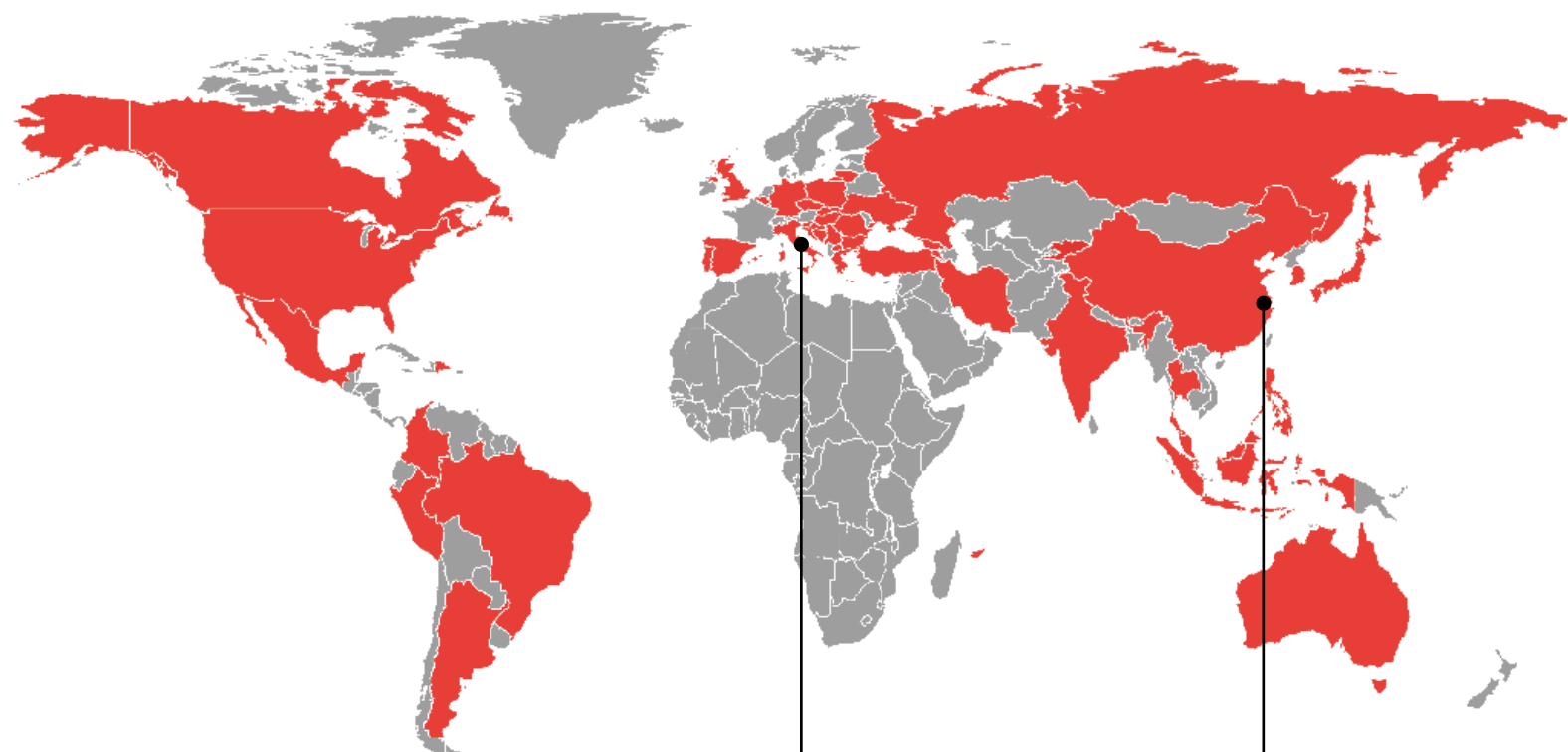

DOVE OPERIAMO
WHERE WE WORK



RAIL SRL
VIA A. GRANDI, 16
42030 VEZZANO SUL CROSTOLO (RE)
ITALIA



+39 0522 603801



info@railspa.net



XIAOLEI YANG
ILLA 26, NO. 333 HONGDE ROAD,
JIADING DIST. SHANGHAI 201800
CHINA



+86 186 0175 4557



jyang@railspa.net



Dal 2014) Fornitura degli iniettori IG1, IG1 Apache e IG7 ad OEM Cinesi

From 2014) Supply of injectors IG1, IG1 Apache and IG7 to Chinese OEM

2014) IG1 Apache HD/ IG1 2014: incrementata durata ed affidabilità del prodotto di conseguenza aumentato il periodo di garanzia

2014) IG1 Apache HD / IG1 2014: increasing of durability and reliability of products consequently increased the period of warranty

2016) 3.000.000 di iniettori 4,3 e 2 cilindri venduti dal 2006

2016) 3.000.000 of 4,3 and 2 cylinders injectors sold since 2006

2016) IG1 Apache HD raggiungono 150.000 km su un lotto di taxi in Thailandia senza alcun intervento di manutenzione

2016) IG1 Apache HD has reached 150.000 km on a batch of taxi in Thailand without making any maintenance

2016) IG7 Dakota raggiunge 1 miliardo di cicli nel test di durata in laboratorio

2016) IG7 Dakota has reached 1 billion cycles on durability test made in laboratory

2016) IG1 Apache HD/ IG1 2014: nessun reclamo relativo alle prestazioni o durata dal 2014

2016) IG1 Apache HD / IG1 2014: no any claims related to performance or durability from 2014

2016) RAIL festeggia il decimo anniversario

2016) RAIL celebrates tenth anniversary



Progettazione Design

Riduttore Metano CNG Reducer

Una delle novità, sarà il nuovo riduttore metano, un riduttore, che a nostro avviso sarà di grande interesse sul mercato dovuto alla sua forma e alle sue caratteristiche.

One of the news will be the new CNG reducer, that in our opinion will be interesting on the market due to its form and features.

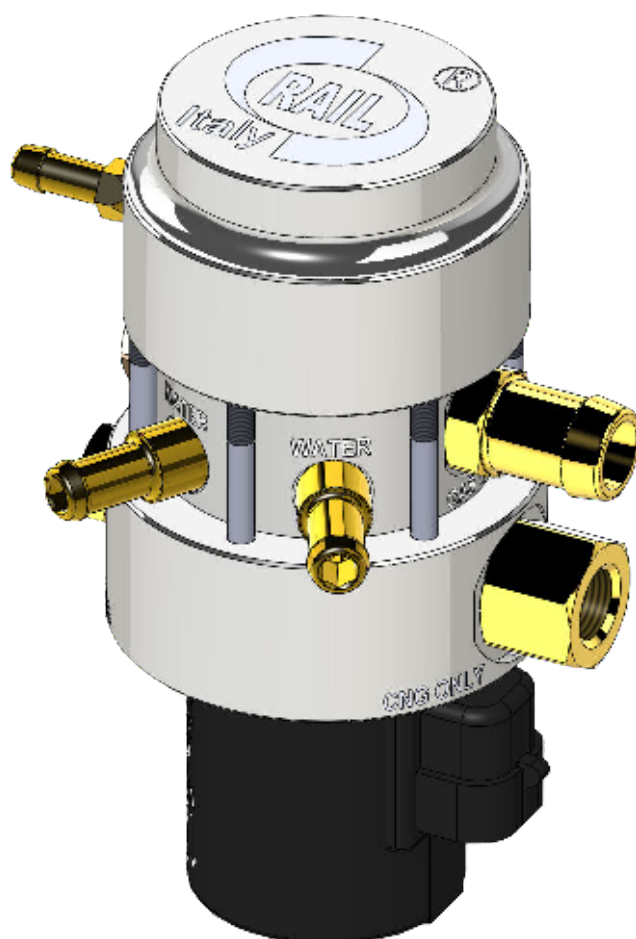

Iniettoriduttore Injectoreducer



Co-funded by the Horizon 2020 programme
of the European Union

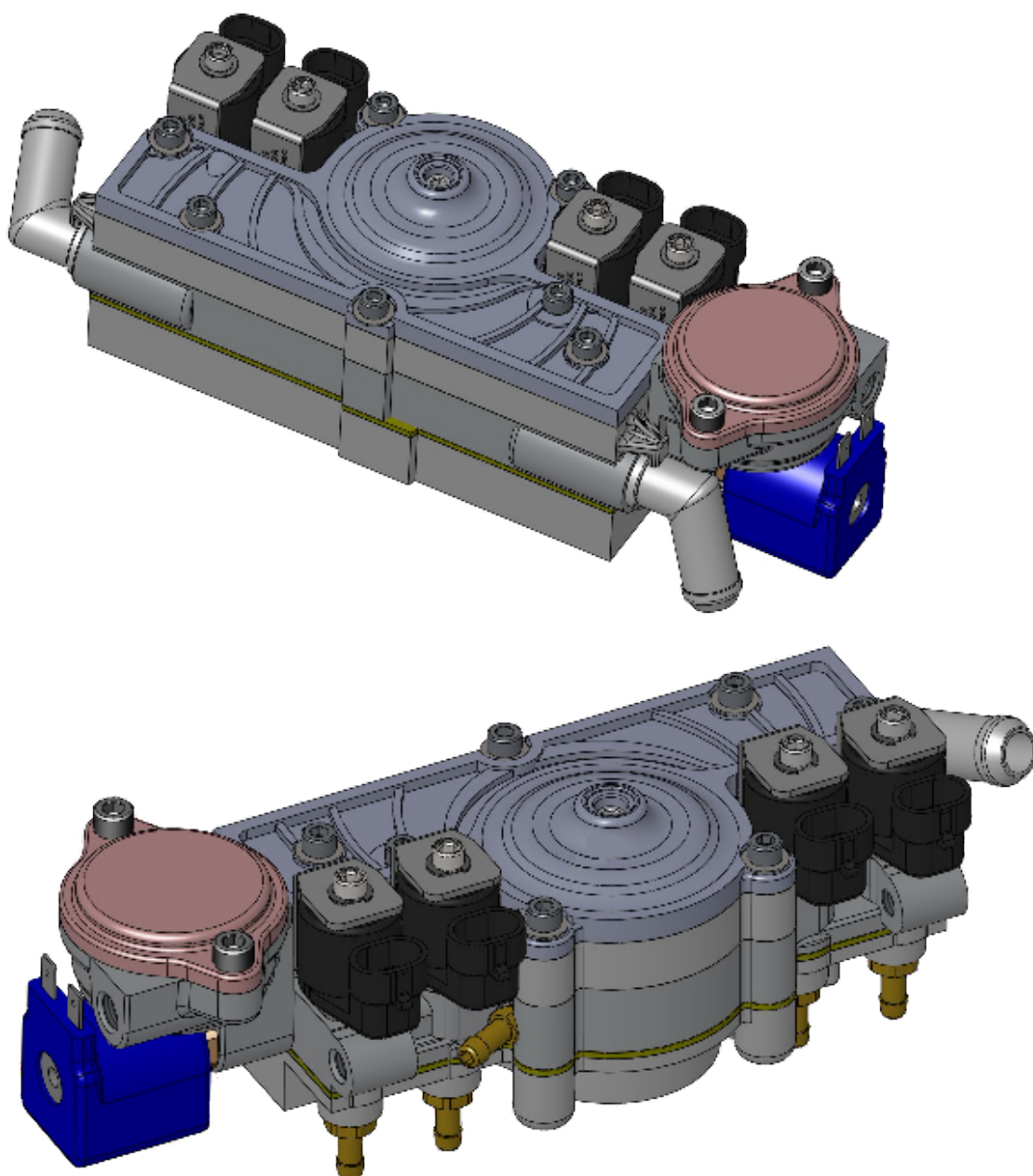

Siamo fieri di annunciare che il nostro progetto denominato "Iniettoriduttore", ha ottenuto il riconoscimento da parte della Comunità Europea nell'ambito del programma di sviluppo **Horizon 2020-SME Inst-2016-2017 small business innovation research for trasport and Smart Cities Mobility Phase 1**.

We are proud to announce that our project called "Injectoreducer" has obtained the admission from European Community for the development program **Horizon 2020-SME Inst-2016-2017 small business innovation research for trasport and Smart Cities Mobility Phase 1**



Personalizzazioni Customizations



-  Nero
Black
-  Verde
Green
-  Rosso
Red
-  Blu
Blue
-  Grigio
Grey
-  Arancione
Orange
-  Grigio Scuro
Dark Grey
-  Giallo
Yellow

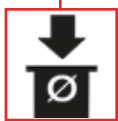
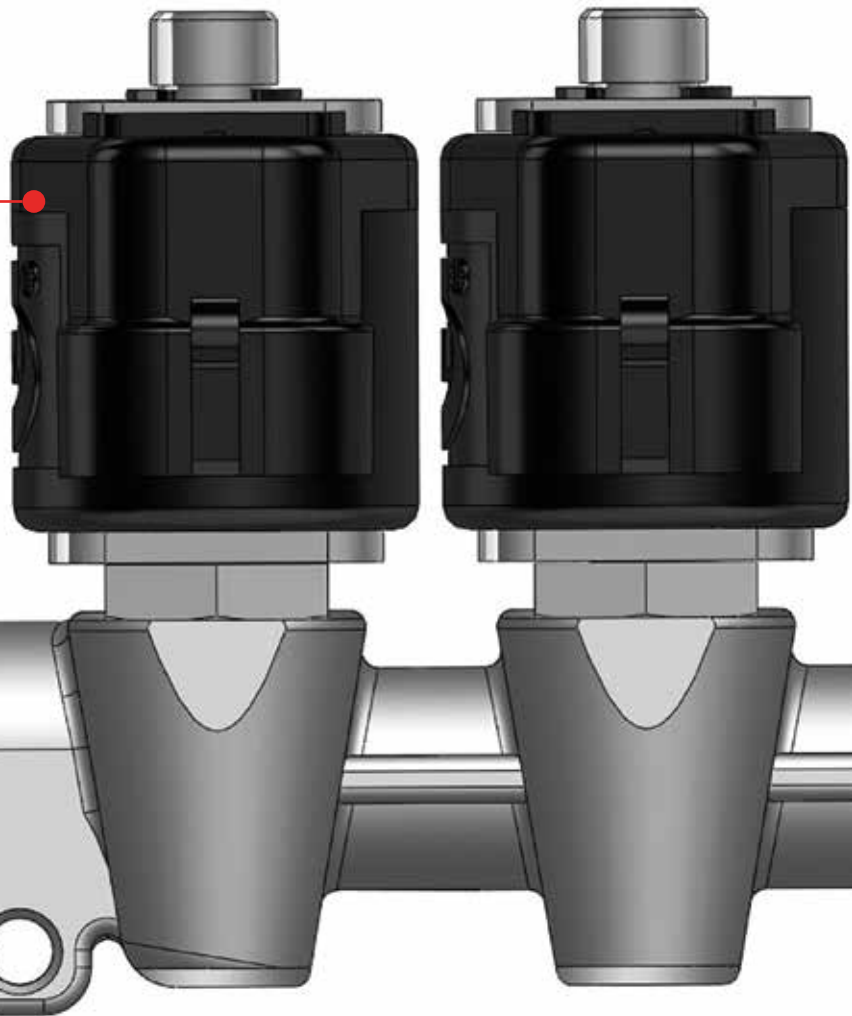

PERSONALIZZAZIONE DIAMETRO
DIAMETER CUSTOMIZATION

LB
custom

PERSONALIZZAZIONE LOGO
LOGO CUSTOMIZATION



LG
custom

PERSONALIZZAZIONE LOGO
LOGO CUSTOMIZATION

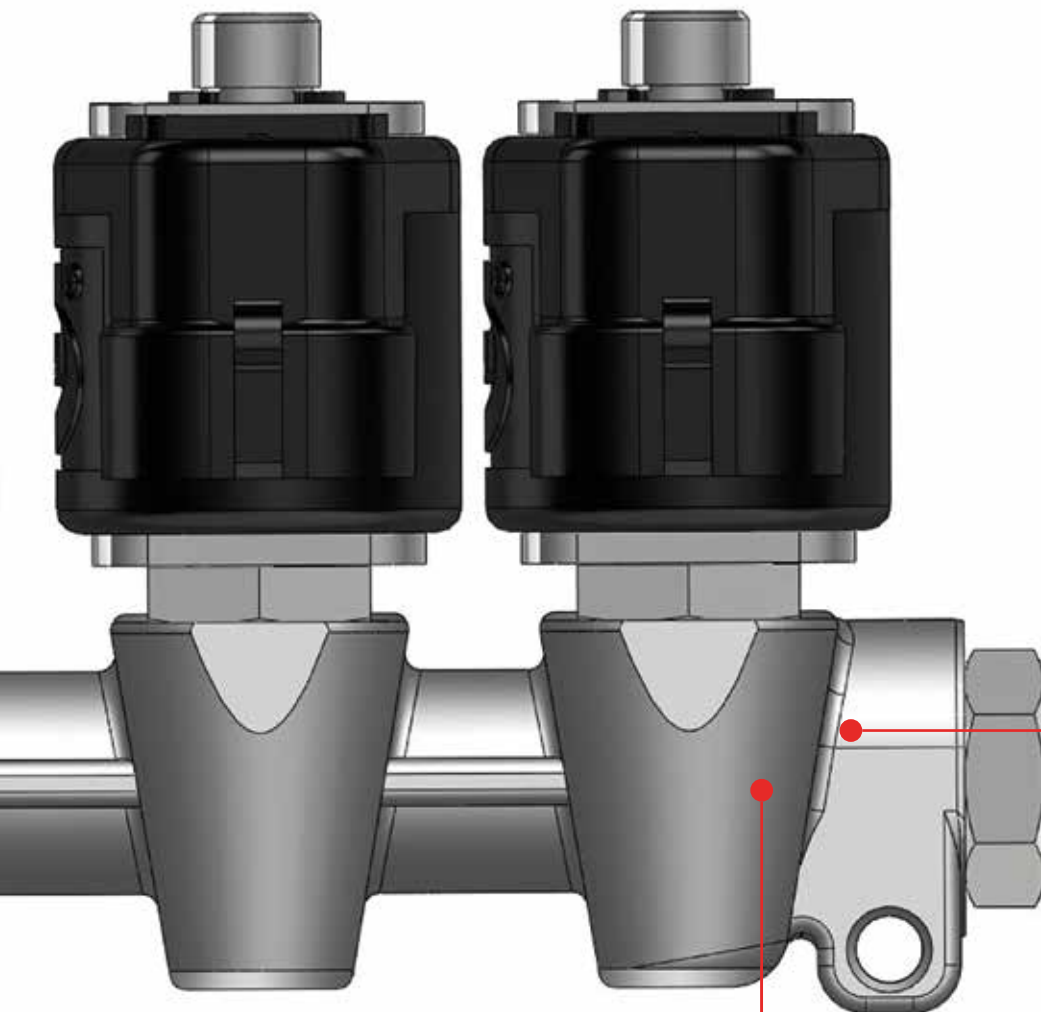

ALLUMINIO
ALUMINIUM

AI
aluminium

Neutro
Neutral

Nero
Black

Rosso
Red

Blu
Blue

Verde
Green

PERSONALIZZAZIONE ETICHETTA
LABEL CUSTOMIZATION

LB
custom



Caratteristiche Features

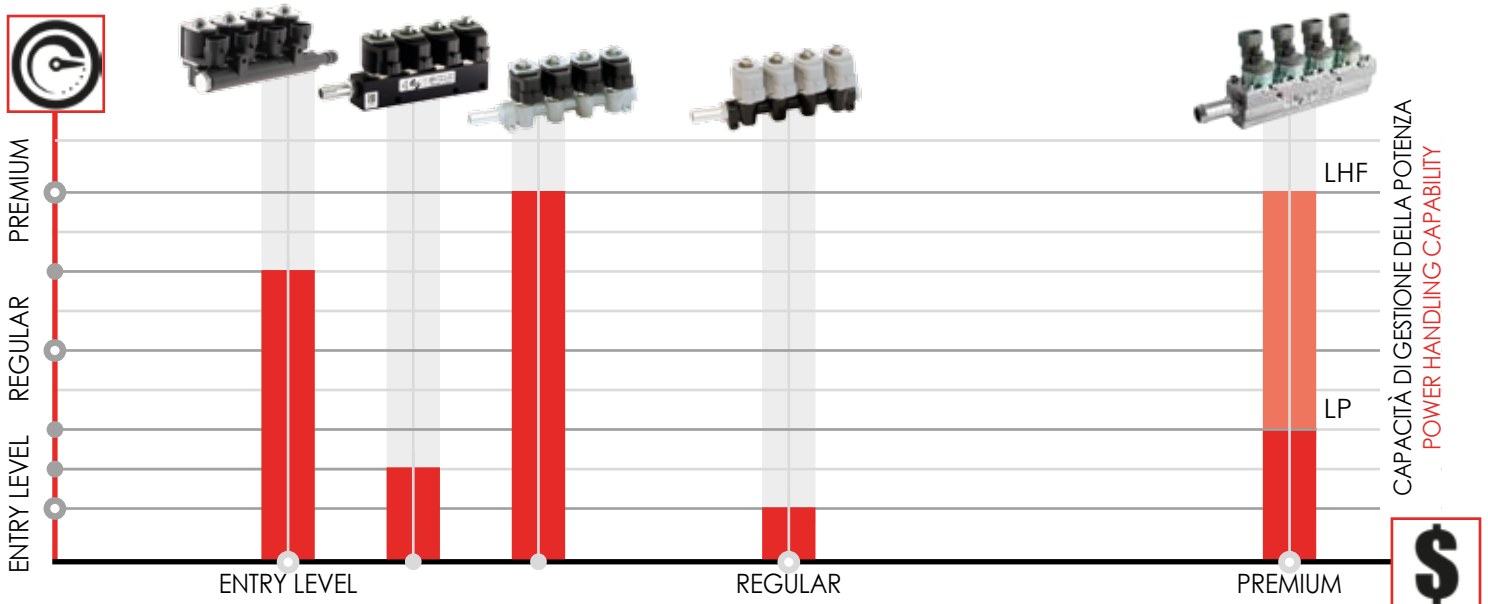
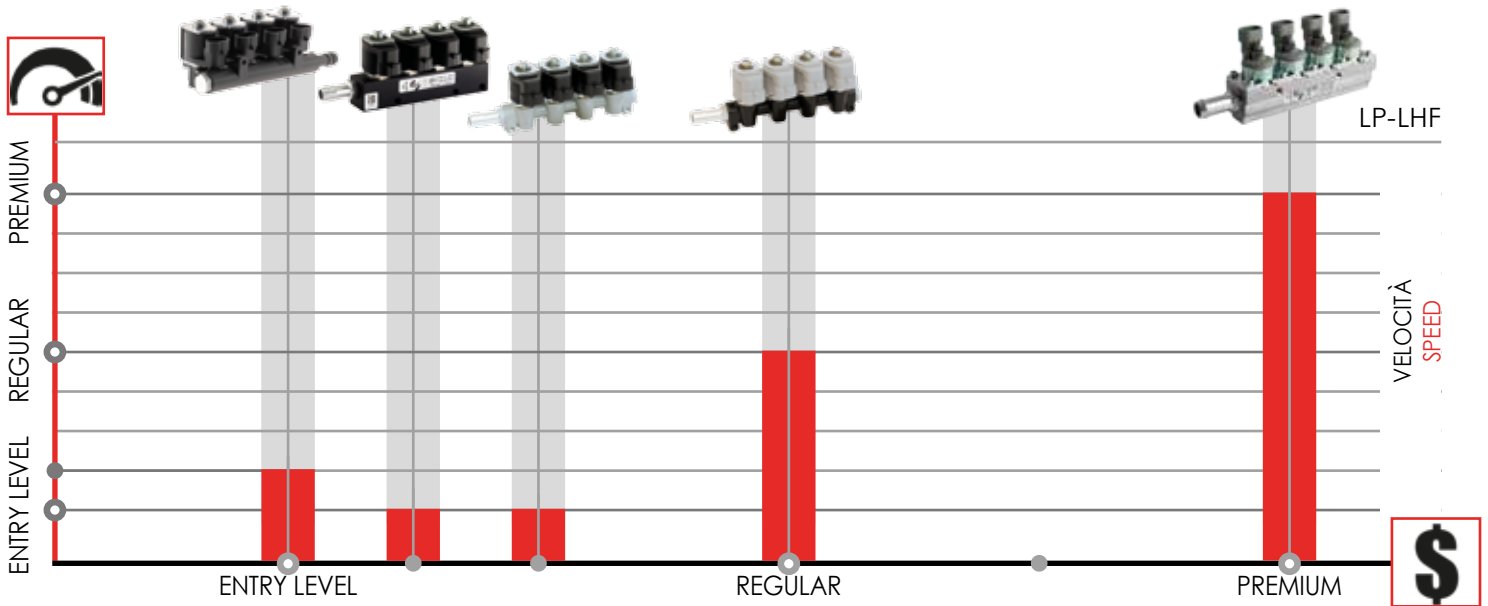
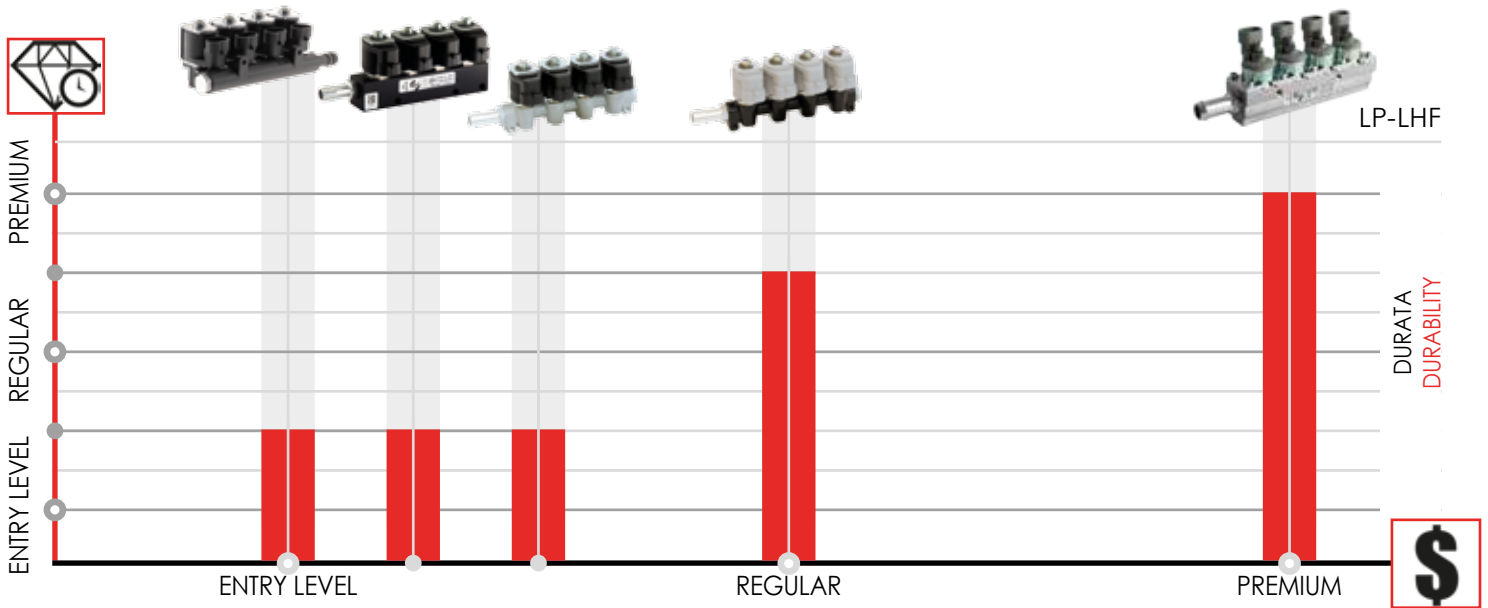

Legenda

Legenda



Elevate prestazione
High performance



Prestazioni nella media
Medium performance



Iniettore tecnologico
High-technology injector



Caratteristica principale
Main feature



Costo
Cost



Base
Entry Level



Normale
Regular



Alto livello
Premium



Accessori
Accessories



Description



Descrizione

Alluminio
Aluminium

Al
aluminium

Materiale polimerico
Polymeric material

Pm
polymer

Ottone
Brass

CuZn
brass

Acciaio
Steel

FeC
steel

Specifiche tecniche
Technical specification

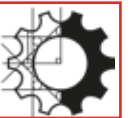

Pressione Lavorativa
Working Pressure



Tensione di Alimentazione
Supply Voltage



Resistenza Bobina ± 5%
Coil Resistance ± 5%



Diametro Raccordo Ingresso Gas
Inlet Gas Fitting Diameter



Diametro Raccordo Uscita Gas
Outlet Gas Fitting Diameter



Gamma Calibrazione Foro
Calibrated Hole Range



Capacità di Gestione Della Potenza
Power Handling Capability



Intervallo di Temperatura
Temperature Range

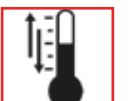

Certificazioni
Approvals





Iniettori per applicazioni GPL/Metano Injectors for LPG/CNG application

IG1 Old

Iniettore per applicazioni GPL/Metano
Injector for LPG/CNG application



INIETTORE STORICO
HISTORICAL INJECTOR



DISPONIBILE NELLA VERSIONE CON CORSA 0,45MM
AVAILABLE VERSION WITH 0,45 MM STROKE



Al
aluminium



From 0,5 to 2,0 bar
MAX 3,0 Bar



10,8 - 14,4 V



A2 2,0 Ohm
A3 3,0 Ohm



Rubber hose D. 10mm/12mm
(D. 14mm/16mm available on request)



Calibrated nozzles M8x1
for rubber hose D. 6mm
(D. 4mm/5mm available on request)



1,0 - 3,25 mm (0,25mm step)



LPG 1 bar 45HP/Cyl
CNG 2 bar 40HP/Cyl



LPG -20° / +120°C
CNG -40° / +120°C



67R-01 / 110R-00 / ISO15500



Sensore Temperatura M5
Temperature Sensor M5



Sensore di pressione e temperatura Sensata
Pressure and Temperature sensors Sensata



Staffa di fissaggio
Fixing bracket

IG1 Apache

Iniettore per applicazioni GPL/Metano

Injector for LPG/CNG application



ALTA CAPACITÀ DI GESTIONE DELLA POTENZA
HIGH POWER HANDLING CAPABILITY



CORPO STILIZZATO
STYLIZED BODY



Al
aluminium



From 0,5 to 2,0 bar
MAX 3,0 Bar



10,8 - 14,4 V



A2 2,0 Ohm
A3 3,0 Ohm



Rubber hose D. 10mm/12mm
(D. 14mm/16mm available on request)



Calibrated nozzles M8x1
for rubber hose D. 6mm
(D. 4mm/5mm available on request)



1,0 - 3,25 mm (0,25mm step)



LPG 1 bar 63HP/Cyl
CNG 2 bar 52HP/Cyl



LPG -20° / +120°C
CNG -40° / +120°C



67R-01 / 110R-00 / ISO15500



Sensore Temperatura M5
Temperature Sensor M5



Sensore di pressione e temperatura Sensata
Pressure and Temperature sensors Sensata



Staffa di fissaggio
Fixing bracket

IG1 Apache HD

Iniettore per applicazioni GPL/Metano
Injector for LPG/CNG application



INIETTORE VELOCE
FAST INJECTOR



COMPONENTI MECCANICI IN ACCIAIO INOX
MECHANICAL COMPONENTS IN STAINLESS STEEL



From 0,5 to 2,0 bar
MAX 3,0 Bar



10,8 - 14,4 V



A2 2,0 Ohm



Rubber hose D. 10mm/12mm
(D. 14mm/16mm available on request)



Calibrated nozzles M8x1
for rubber hose D. 6mm
(D. 4mm/5mm available on request)



1,0 - 2,75 mm (0,25mm step)



LPG 1 bar 45HP/Cyl
CNG 2 bar 40HP/Cyl



LPG -20° / +120°C
CNG -40° / +120°C



67R-01 / 110R-00 / ISO15500



Sensore Temperatura M5
Temperature Sensor M5



Sensore di pressione e temperatura Sensata
Pressure and Temperature sensors Sensata



Staffa di fissaggio
Fixing bracket

IG2

Iniettori per applicazioni GPL/Metano

Injector for LPG/CNG application

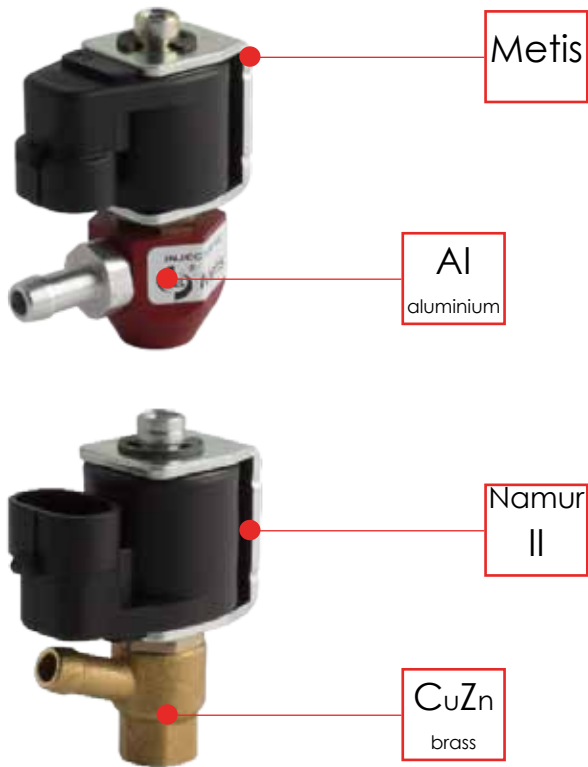

INIETTORE SINGOLO
SINGLE INJECTOR



From 0,5 to 2,0 bar
MAX 3,0 Bar



10,8 - 14,4 V



A2 2,0 Ohm
A3 3,0 Ohm



On Manifold

Rubber hose D. 10mm/12mm
(D. 14mm/16mm available on request)



From Manifold to injector inlet

Rubber hose D.7mm



Calibrated nozzles M8x1
for rubber hose D. 6mm
(D. 4mm/5mm available on request)



1,0 - 3,25 mm (0,25mm step)



LPG 1 bar 50HP/Cyl
CNG 2 bar 45HP/Cyl



LPG -20° / +120°C
CNG -20° / +120°C



67R-01 / 110R-00



Manifold



Sensore di pressione e temperatura Sensata
Pressure and Temperature sensors Sensata

IG5 Noumea

Iniettori per applicazioni GPL/Metano

Injector for LPG/CNG application



Pm
polymer



From 0,5 to 2,0 bar
MAX 3,0 Bar



10,8 - 14,4 V



A2 2,0 Ohm
A3 3,0 Ohm



Rubber hose D. 10mm/12mm
(D. 14mm/16mm available on request)
D.7 mm (only for single version)



Calibrated nozzles for rubber hose D.6mm
Available nozzle for direct mounting on engine manifold
(for single injector only)



1,0 - 3,50 mm (0,25mm step)



LPG 1 bar 60HP/Cyl
CNG 2 bar 50HP/Cyl



LPG -20° / +120°C
CNG -20° / +120°C
LPG / CNG Single Version -40° / +120°C



67R-01 / 110R-00



Sensore Temperatura M5
Temperature Sensor M5



Sensore di pressione e temperatura Sensata
Pressure and Temperature sensors Sensata



Staffa di fissaggio
Fixing bracket



Ugello montaggio diretto
Nozzle for direct mounting

IG7 Dakota LP & LHF

Iniettore per applicazioni GPL/Metano

Injector for LPG/CNG application



Al
aluminium



From 0,5 to 3,0 bar
MAX 4,5 Bar



10,8 - 14,4 V



E2 2,0 Ohm



Rubber hose D. 10mm/12mm
(D.14mm/16mm available on request)



Calibrated nozzles M8x1
for rubber hose D.6mm



LP 1,0 - 3,25 mm (0,25mm step)
LHF 1,0 - 3,50 mm (0,25mm step)



LP LPG 1 bar 40HP/Cyl **LHF LPG** 1 bar 60HP/Cyl
LP CNG 2 bar 35HP/Cyl **LHF CNG** 2 bar 50HP/Cyl



LPG -40° / +120°C
CNG -40° / +120°C



67R-01 / 110R-00



Staffa di fissaggio
Fixing bracket

Sensore di pressione e temperatura Sensata
Pressure and Temperature sensors Sensata



Iniettori GPL/Metano per veicoli pesanti
LPG/CNG Injectors for heavy duty vehicles

IG6 Taurus

Iniettore dedicato alla conversione da Diesel a GPL/Metano per veicoli pesanti
Injector dedicated for conversion from Diesel to LPG/CNG for heavy vehicles



INIETTORE SINGLE POINT
SINGLE POINT INJECTOR



AI
aluminium



Version at 5,0 and 9,0 Bar



10,8 - 14,4 V



E2 2,0 Ohm



Rubber hose D. 10mm/12mm
(D.14mm/16mm available on request)



LPG -20° / +120°C
CNG -20° / +120°C



Sensore di pressione e temperatura Sensata
Pressure and Temperature sensors Sensata

IG6 Potomac

Iniettore dedicato alla conversione da Diesel a GPL/Metano per veicoli pesanti
Injector dedicated for conversion from Diesel to LPG/CNG for heavy vehicles



INIETTORE A CARTUCCIA DA COMBINARE CON UN MIXER
CARTRIDGE INJECTOR TO BE MATCHED WITH A MIXER



CORPO IN ACCIAIO ZINCATO
GALVANIZED STEEL BODY



Esempio di mixer
Example of mixer



Up to 5 Bar



10,8 - 14,4 V



E5 1,5 Ohm



LPG -20° / +120°C
CNG -20° / +120°C



110R-00



Sensore di pressione e temperatura Sensata
Pressure and Temperature sensors Sensata

IG7 Dakota HP

Iniettore per applicazioni GPL/Metano

Injector for LPG/CNG application



Al
aluminium



From 0,5 to 7,0 bar
MAX 9,0 Bar



10,8 - 14,4 V



E2 2,0 Ohm



Rubber hose D. 10mm/12mm
(D.14mm/16mm available on request)



Calibrated nozzles M8x1
for rubber hose D.6mm



1,0 - 2,0 mm (0,25mm step)



CNG 7 bar 64HP/Cyl



CNG -40° / +120°C



110R-00





Filtri GPL/Metano LPG/CNG Filters

FG3

Filtro GPL/Metano
LPG/CNG Filter



ELEMENTO FILTRANTE IN CARTA RESINATA
FILTERING ELEMENT MADE OF RESINATED PAPER



Rubber hose D. 10mm/12mm/14mm/16mm



LPG -20° / +120°C
CNG -20° / +120°C

FG4

Filtro GPL/Metano
LPG/CNG Filter



ISPEZIONABILE
EXCHANGEABLE



SISTEMA A VORTICE PER SEPARARE ELEMENTI DI OLIO DAL GAS
VORTEX SYSTEM TO SEPARATE OIL ELEMENTS FROM GAS



ALLOGGIO PER SENSORI BOSCH O CONTINENTAL / SIEMENS
SPECIAL SEAT FOR BOSCH OR CONTINENTAL/SIEMENS SENSOR



Rubber hose D. 12mm



LPG -40° / +120°C
CNG -40° / +120°C



Cartuccia filtrante di ricambio con o-rings
Filter cartridge with o-rings



Elettrovalvola GPL LPG Solenoid valve

VG6

Elettrovalvola per applicazioni GPL

Solenoid valve for LPG application



Max 3 MPa



12V DC



12,3 Ohm



M10x1 Female



M10x1 Female



LPG -20° / +120°C



ECE 67R-01



Staffa di fissaggio
Fixing bracket



Cavetto cablato L=500mm con connettore maschio porta femmina AMP superseal per collegamento bobine

Wired cable L=500mm, with male connector, AMP superseal female holder for connecting ignition coils.



Tubo termoplastico GPL
LPG thermoplastic hose

Tubo termoplastico GPL LPG thermoplastic hose



ANIMA INTERNA IN POLIAMMIDE, RINFORZO CON SINGOLA
TRECCIA IN FILATO TESSILE E RIVESTIMENTO ESTERNO IN
POLIURETANO
INTERNAL CORE IN POLYAMIDE, REINFORCEMENT WITH A
TEXTILE FIBER AND EXTERNAL COVERING IN ANTI-ABRASION
POLYURETHANE



3/16" Internal diameter 4.8 mm
1/4" Internal diameter 6.4 mm



3/16" External diameter 9.2 mm
1/4" External diameter 10.8 mm



Max working pressure 30 Bar



LPG -40° / +125°C



67R-01

Disponibile anche in versione "KIT" e composto con i seguenti componenti.

- KIT TUBO TERMOPLASTICO "Raccordo Dritto" D.6 mm e D.8 mm

6mt Tubo termoplastico 6 mm o D. 8 mm

2x raccordo dritto D. 6 mm o D. 8 mm

2x ogiva D. 6 mm o D. 8 mm

2x dado D. 6 mm o D. 8 mm

- KIT TUBO TERMOPLASTICO "Raccordo 90°" D.6 mm e D.8 mm

6mt Tubo termoplastico D. 6 mm o D. 8 mm

1x raccordo dritto D. 6 mm o D. 8 mm

1x raccordo 90° D. 6 mm o D. 8 mm

2x ogiva D. 6 mm o D. 8 mm

2x dado D. 6 mm o D. 8 mm

Available also in "KIT" version and composed with the following component

- THERMOPLASTIC HOSE KIT "Straight Fitting" D.6 mm and D.8 mm

6mt Thermoplastic hose D. 6 mm or D. 8 mm

2x straight fitting D. 6 mm or D. 8 mm

2x conical ring D. 6 mm or D. 8 mm

2x nut D. 6 mm or D. 8 mm

- THERMOPLASTIC HOSE KIT "90° Fitting" D.6 mm and D.8 mm

6mt Tubo termoplastico 6 mm o D. 8 mm

1x straight fitting D. 6 mm or D. 8 mm

1x 90° fitting D.6 mm or D. 8 mm

2x conical ring D. 6 mm or D. 8 mm

2x nut D. 6 mm or D. 8 mm

Accessori per tubo termoplastico GPL Accessories for LPG thermoplastic hose



Raccordo dritto codolo liscio, disponibile nelle seguenti versioni

Straight fitting, available in the following version

Tipo / Type: Ø 6mm - Uscita / Outlet: Ø 6mm

Tipo / Type: Ø 6mm - Uscita / Outlet: Ø 8mm

Tipo / Type: Ø 8mm - Uscita / Outlet: Ø 8mm

Tipo / Type: Ø 8mm - Uscita / Outlet: Ø 6mm



Raccordo a 90° codolo liscio, disponibile nelle seguenti versioni

90° fitting, available in the following version

Tipo / Type: Ø 6mm - Uscita / Outlet: Ø 6mm

Tipo / Type: Ø 6mm - Uscita / Outlet: Ø 8mm

Tipo / Type: Ø 8mm - Uscita / Outlet: Ø 8mm

Tipo / Type: Ø 8mm - Uscita / Outlet: Ø 6mm



Ogiva, disponibile per tubi D. 6mm e D. 8mm

Cornical ring, available for D. 6mm and D. 8mm hose



Dado, disponibile per tubi D. 6mm e D. 8mm

Nut, available for D. 6mm and D. 8mm hose



Collare stringi tubo, disponibile per tubi D. 6mm e D. 8mm

Collar Clamps, available for D. 6mm and D. 8mm hose



Extra
Extras

Calibratore singola sede Single seat calibrator

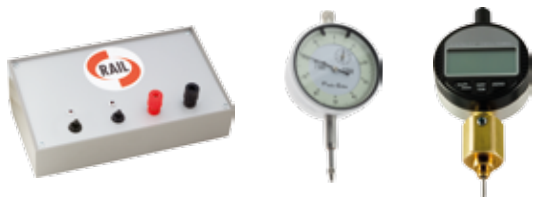

Attrezzo manuale per misurare la corsa della singola sede per iniettori IG1, IG1 Apache, IG1 Apache HD, IG2 Namur II, IG2 Metis, IG3 Horizon, IG5 Noumea e IG7 Dakota

Manual tool designed to calibrate and set the single seat, for injector IG1, IG1 Apache, IG1 Apache HD, IG2 Namur II, IG2 Metis, IG3 Horizon, IG5 Noumea and IG7 Dakota

Sistema di pulizia iniettori Injector cleaning system



Kit pulizia iniettori GPL/Metano studiato in modo da poter eseguire la completa pulizia degli iniettori senza che gli stessi vengano smontati dal veicolo. Universale per tutti gli iniettori e sistemi sequenziali GPL/Metano che lavorano fino ad una pressione di max 4/5 bar

Cleaning kit for LPG and Natural Gas injectors designed to clean injectors thoroughly without disassembling them from the vehicle. Suitable for all LPG and Natural Gas injectors and sequential systems operating up to a maximum pressure of 4/5 Bar

BREVETTATO
PATENTED

Riscaldatore per iniettori Heater for injectors



Riscaldatore da posizionare a contatto con il corpo dell'iniettore IG1 e IG1 Apache, controllato

da un sensore di temperatura ed un regolatore elettronico avanzato che controlla le operazioni solo se necessario, per evitare inutili sprechi di consumo e una possibile temperatura troppo alta. Facile da montare e smontare, non ha bisogno di manutenzione. Questo dispositivo è in grado di ridurre e risolvere i problemi di collosità nella sede dell'iniettore e facilita il movimento interno quando l'iniettore stesso è sporco.

Heating to place in contact with the IG1 and IG1 Apache injector body, controlled by a temperature sensor and an advanced electronic controller that controls operation only if necessary, to avoid useless current consumption and a possible too high temperature. Easy to mount and dismount, it doesn't need maintenance. This device can reduce and solve sticking problem on the injector seat and facilitates internal plunger movements when injector is dirty.

Injector Temperature at -20° C ambient T

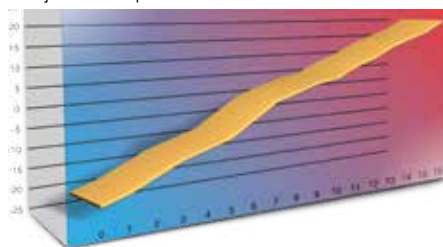

Il diagramma mostra il calore ottenuto dall'unico riscaldatore (senza l'influenza del calore del motore o di gas ridotto).

The diagram show heating given from the only heater (without contribution from engine's heat or from heated reducer gas)



Accessori
Accessories

Ugelli Nozzles



Ugello calibrato in ottone per iniettori IG1, IG1 Apache, IG1 Apache HD, IG2 Metis, IG2 Namur II, IG3 Horizon e IG7 Dakota

Calibrated nozzle in brass for injectors IG1, IG1 Apache, IG1 Apache HD, IG2 Metis, IG2 Namur II, IG3 Horizon and IG7 Dakota



Ugello per montaggio diretto su collettore per iniettore IG5 Noumea singolo

Nozzle for direct mounting on intake manifold for injector IG5 Noumea single



Ugello calibrato in alluminio per iniettore IG5 Noumea

Calibrated nozzle in aluminium for injector IG5 Noumea



Ugello collettore 90° per ogni tipo di applicazione sequenziale. Migliora il rendimento e la qualità della miscelazione tra aria e gas

90° Intake manifold nozzle for all types of sequential application. It improves efficiency and quality of mixing between air and gas



Ugello collettore lungo, utilizzabile per collettori d'aspirazione di grandi dimensioni e per presa lettura MAP

Long intake manifold nozzle, usable for big size intake manifold or for MAP connection

Raccordi Connectors



Raccordo per tubi gomma D.5mm/6mm per presa MAP M12x1. Per iniettori IG1, IG1 Apache, IG1 Apache HD, IG5 Noumea e IG7 Dakota

MAP connector for rubber hose D.5mm/6mm M12x1. For injectors IG1, IG1 Apache, IG1 Apache HD, IG5 Noumea and IG7 Dakota



Raccordo a Y in resina termoplastica per tubi D.5mm/10mm/12mm

Y-connector made of thermoplastic resin for rubber hose D.5mm/10mm/12mm



Cavetto cablato L=500mm con connettore maschio porta femmina AMP Superseal per collegamento bobine iniettori

Wired cable L=500mm with male connector to female AMP Superseal for connecting injector ignition coils



Raccordo di ingresso gas M12x1 per tubi D.10mm per iniettori IG1, IG1 Apache, IG1 Apache HD e IG7 Dakota

Gas inlet connector M12x1 for rubber hose D.10mm for injectors IG1, IG1 Apache, IG1 Apache HD and IG7 Dakota



Adattatore M12x1 per sensore di pressione e temperatura Sensata per iniettori IG1, IG1 Apache, IG1 Apache HD, IG5 Noumea e IG7 Dakota

Adaptor M12x1 for Sensata pressure and temperature sensor for injectors IG1, IG1 Apache, IG1 Apache HD, IG5 Noumea and IG7 Dakota



Raccordo di ingresso gas per tubi D.7mm per iniettori IG5 Noumea

Gas inlet connector for rubber hose D.7mm for injector IG5 Noumea



Raccordo di ingresso gas M12x1 per tubi D.14mm per iniettori IG1, IG1 Apache, IG1 Apache HD e IG7 Dakota

Gas inlet connector M12x1 for rubber hose D.14mm for injector IG1, IG1 Apache, IG1 Apache HD and IG7 Dakota

Sensori Sensors



Raccordo per tubo di gomma interno D. 5 o 6mm per presa segnale di pressione all'uscita dell'iniettore, con integrato sensore di temperatura NTC 4.7 kOhm per iniettori IG1, IG1 Apache, IG1 Apache HD, IG5 Noumea e IG7 Dakota

Pipe fitting for internal rubber pipe diameter size 5 or 6mm for pressure signal outlet on the injector's outlet, with included temperature sensor NTC 4.7 kOhm. for injectors IG1, IG1 Apache, IG1 Apache HD, IG5 Noumea and IG7 Dakota



Raccordo per tubo di gomma interno dia. 5 o 6mm per presa segnale di pressione all'uscita dell'iniettore, con integrato sensore di temperatura NTC 4.7 kOhm con connettore AMP per iniettori IG1, IG1 Apache, IG1 Apache HD, IG5 Noumea e IG7 Dakota

Pipe fitting for internal rubber pipe D. 5 or D. 6mm for pressure signal outlet on the injector's outlet, with included temperature sensor NTC 4.7 kOhm with AMP Connector for injectors IG1, IG1 Apache, IG1 Apache HD, IG5 Noumea and IG7 Dakota



Raccordo per tubo di gomma interno dia. 5 o 6mm per presa segnale di pressione all'uscita dell'iniettore, con integrato sensore di temperatura NTC 4.7 kOhm con connettore SICMA II per iniettori IG1, IG1 Apache, IG1 Apache HD, IG5 Noumea e IG7 Dakota

Pipe fitting for internal rubber pipe D. 5 or D. 6mm for pressure signal outlet on the injector's outlet, with included temperature sensor NTC 4.7 kOhm with SICMA II Connector for injectors IG1, IG1 Apache, IG1 Apache HD, IG5 Noumea and IG7 Dakota



Sensore di temperatura M5 NTC 4,7 KOhm fili spelati per iniettori IG1, IG1 Apache, IG1 Apache HD, IG5 Noumea e IG7 Dakota

Temperature sensor M5 NTC 4,7KOhm pig tail for injectors IG1, IG1 Apache, IG1 Apache HD, IG5 Noumea and IG7 Dakota



Sensore di temperatura M5 NTC 4,7 KOhm con connettore AMP per iniettori IG1, IG1 Apache, IG1 Apache HD, IG5 Noumea e IG7 Dakota

Temperature sensor M5 NTC 4,7KOhm with AMP connector for injectors IG1, IG1 Apache, IG1 Apache HD, IG5 Noumea and IG7 Dakota



Sensore di temperatura M5 NTC 4,7 KOhm con connettore SICMA II per iniettori IG1, IG1 Apache, IG1 Apache HD, IG5 Noumea e IG7 Dakota

Temperature sensor M5 NTC 4,7KOhm with SICMA II connector for injectors IG1, IG1 Apache, IG1 Apache HD, IG5 Noumea and IG7 Dakota



Sensore di temperatura e pressione Sensata AMP Micro

Sensata pressure and temperature sensor AMP Micro



Cavetto cablato AMP L=230mm per sensore Sensata

AMP wired cable L=230mm for Sensata sensor

Staffe Bracket



Staffa di fissaggio

Fixing Bracket

Kit di riparazione Repair kit



Kit di ricambio per iniettori IG1 Old, IG1 Apache, IG1 Apache HD, IG2 Namur II e IG2 Metis 4 cilindri composto da 4x nucleo mobile completo, 4x molla e 4x O-ring canotto.

Replacement kit for injector IG1 Old, IG1 Apache, IG1 Apache HD, IG2 Namur II and IG2 Metis 4 cylinders made up of 4x mobile plunger, 4x spring and 4x O-ring sleeve.



Kit di ricambio per iniettori IG5 Noumea 4 cilindri composto da 4x nucleo mobile completo, 4x molla e 4x O-ring canotto.

Replacement kit for injector IG5 Noumea 4 cylinders made up of 4x plunger, 4x spring and 4x O-ring sleeve.



Cartuccia filtrante di ricambio con o-rings per filtro tipo FG4

Spare filter cartridge with o-rings for FG4 filter

Manifold Manifold



Manifolds per utilizzo con iniettori singoli IG2 Metis, IG2 Namur II, IG5 Noumea e IG3 Horizon. Diametri disponibili 10-12-14-16 mm.

Manifolds to use with single injectors IG2 Metis, IG2 Namur, IG2 Namur II, IG5 Noumea and IG3 Horizon. Available diameters 10-12-14-16 mm.



Rail s.r.l.
Via A. Grandi, 16
42030 Vezzano sul Crostolo
Reggio Emilia (RE)
Italy
Tel: +39.0522603801

injector.railgroup.it